

YZ12H/YZ14H

YZ12H 额定功率(Rated Power):110kW@ 2200rpm. 操作重量(Operating Weight):12000Kg.

YZ14H 额定功率(Rated Power):110kW@ 2200rpm. 操作重量(Operating Weight):14000Kg.



- Reasonable configuration, reliable performance, and high working efficiency.
- Rear wheel hydraulic single driving, and stepless T/M.
- Single frequency & dual amplitude, and super centrifugal force, create strong compacting effect.
- Two separate brake systems, safe and reliable.
- Full closed cabin, and 3-stage shock absorption assure comfortable operation.
- Full hydraulic steering system, easy operation and excellent flexibility.



Wheel Loader



Backhoe Loader



Side-shift Backhoe Loader



Vibratory Roller



Pneumatic Roller



Tandem Roller



Motor Grader



Paver



Crane Truck



Concrete Mixer



CHANGLIN®

CHANGLIN COMPANY LIMITED

Add: No.10, Changlin Road, Changzhou, Jiangsu, P.R. of China
P.C.: 213002

Tel: 86-519-86781288 86752400

Fax: 86-519-86781387

Http://www.changlin.com.cn

E-mail: changlinexport@yahoo.com



DEALER:

常林股份有限公司

发动机 (Engine)

	Model	Type	Rated Power/Rated Speed
YZ12H	DongFeng Cummins 6BT5.9	Direct injection, turbocharged, water cooling	110kW@2200rpm
YZ14H	Cummins 6BT5.9(U.K)	Direct injection, turbocharged, water cooling	110kW@2200rpm

振动液压系统(Vibratory Hydraulic System)

开式液压系统, 采用进口的齿轮泵、齿轮马达
Open circuit hydraulic system, adopted imported gear pump and gear motor.
系统压力 Rated pressure.....16MPa

传动系统 (Power Train)

闭式液压系统, 采用进口液压元件, 驱动方式为: 驱动泵+驱动马达+减速箱+驱动桥
Close circuit hydraulic system, adopted imported hydraulic components, Drive pump+drive motor+reducer+drive axle
系统压力 Rated pressure.....40MPa
油泵型号 Model of pump.....A4VG90HWDL1/32R
马达型号 Model of motor.....AA2FM80/61W

行驶性能 (Traveling Performance)

行驶速度 (km/h) (Traveling speed).....0-12.1
最小离地间隙 Min. ground clearance.....395mm
爬坡能力 Gradient capacity.....20%

轮胎 (Tyre)

轮胎尺寸 Tyre size.....23.1-26-12PR

转向系统 (Steering System)

铰接式车架全液压转向.....Articulated frame, full hydraulic steering system
最小转弯半径..... ≤ 5880 mm
Min. steering radius..... ≤ 5880 mm
系统压力 System pressure.....12MPa
转向油缸数-缸径×行程.....2- $\varnothing 90 \times 280$ mm
No. of cylinders-Bore × Stroke.....2- $\varnothing 90 \times 280$ mm

振动轮 (Drum)

	YZ12HD	YZ14HD
静线压力(Static line force)	300N/cm	345N/cm
动线压力(Dynamic line force)	1174N/cm	1370N/cm
Distribution weight of drum	6500Kg	7500Kg
Drum, diameter × width × thickness (mm)	1530 × 2130 × 25	1530 × 2100 × 25

Model	Centrifugal force (Max./min.)	Amplitude (Max./min.)	Frequency
YZ12H	250kN/125kN	1.75/0.85mm	32HZ
YZ14H	292kN/142.5kN	1.8/0.9mm	31HZ

油量 (Refill Capacity)

燃油箱 Fuel tank.....250L
曲轴箱 Crank case.....15L
减速器 Reducer.....2.2L
后桥 Rear axle.....24L
液压系统 Hydraulic system.....200L
振动轮室 Vibrating drum housing (each).....56L

标准配置 (Standard Equipment)

Imported hydraulic components, solenoid vibratory valve

选装件 (Optional Attachment)

Air conditioner, Cold starting device

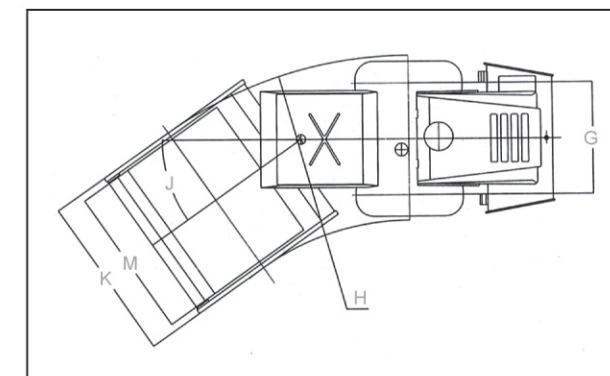
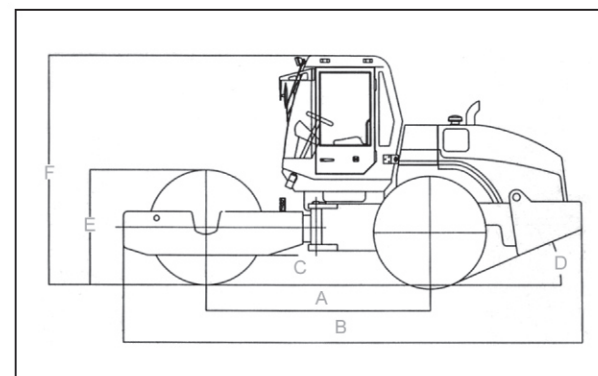

Unit:mm

Model	A	B	C	D	E	F	G	H	J	K	M
YZ12H	2945	6010	395	23°	1530	3055	1560	R5880	35°	2300	2130
YZ14H	2980	6110	395	23°	1530	3055	1560	R5880	35°	2300	2100

Imported Hydraulic Components

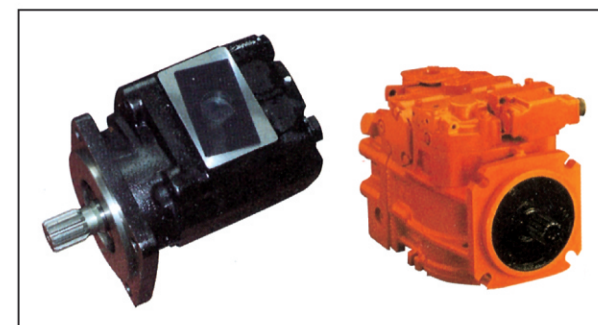

■ Famous brand hydraulic components ensure high reliability.

Perfect Combination

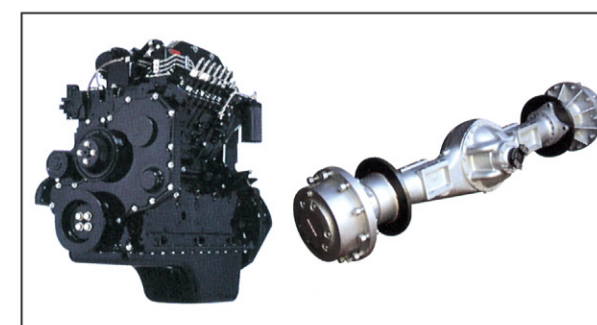

■ Equipped with Cummins engine and CHANGLIN self-made dry-type axle.

Easy Maintenance



■ Engine rear positioning and rear tiltable hood greatly enhance convenience of maintenance

Spacious Cabin



■ Spacious cabin ensure operator a comfortable environment.
■ Direct and simple display of panel is easy and obvious for operator.